



Occam Brick Cladding Facade System



05

About Occam

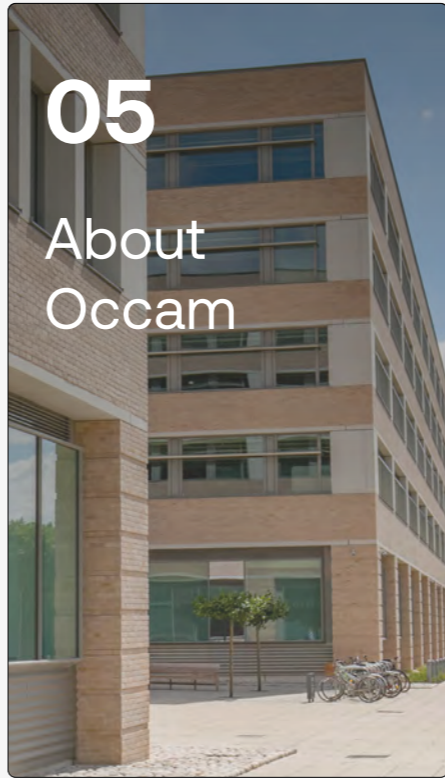

06

Our Systems



08

Testing & Certification



12

Our Components

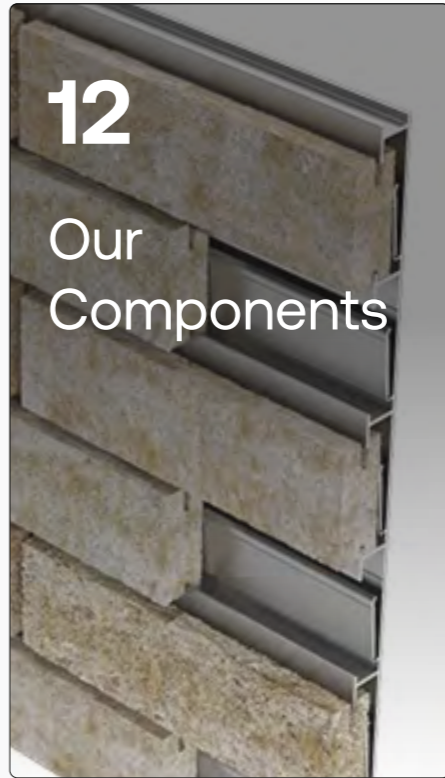

10

Installation Guide



15

Bonding Types

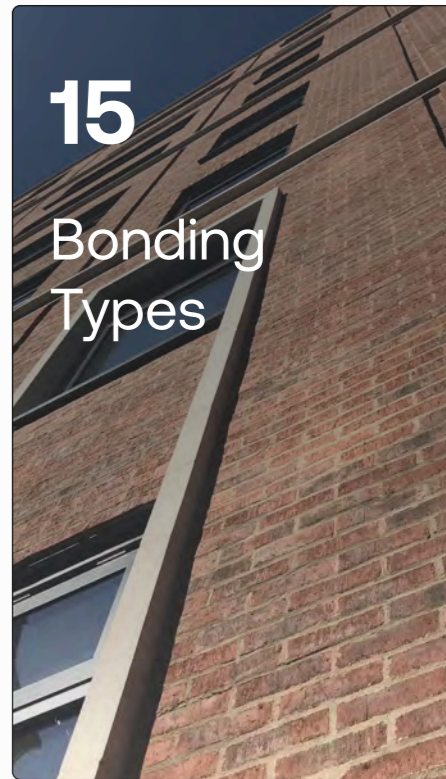

26

Section Drawings

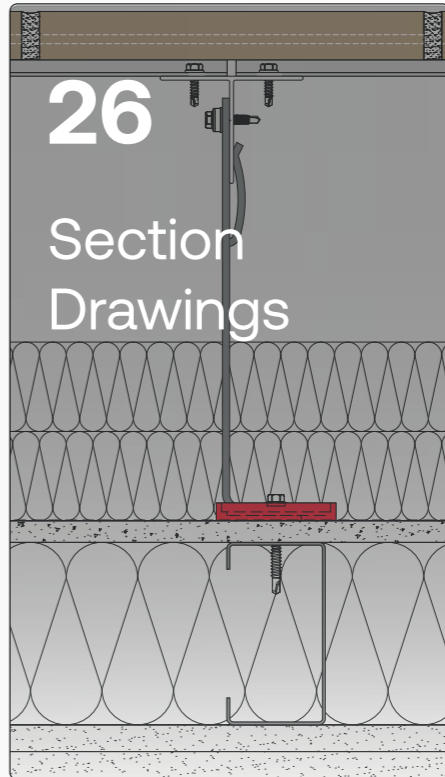

16

Brick Finishes



32

Our Partners

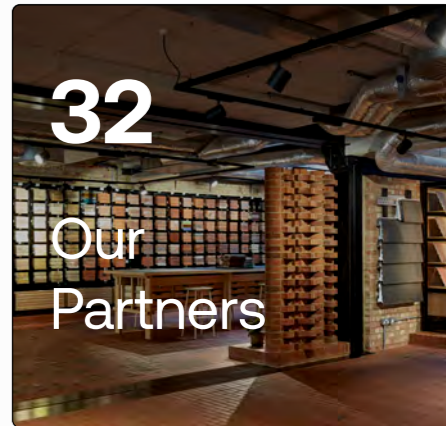



The beauty of brick cladding with refined solutions.

Inspired by Occam's Razor: the principle of simplicity, our system cuts through complexity to deliver the most elegant answer to architectural challenges.

Occam exceeds traditional limitations, offering exquisite design flexibility across traditional brick slips and contemporary clay tiles. Our mechanically fixed rainscreen system fearlessly accommodates bricks from virtually any manufacturer, empowering architects to realise everything from rustic, historic textures to crisp, contemporary lines. Occam combines unparalleled aesthetic versatility with robust performance.

A1 Non-Combustible Systems

Bricks From The Worlds Largest Manufacturers

Compliant With CWCT Standards

UL 3rd Party Product Certification

Mechanically Fixed Brick

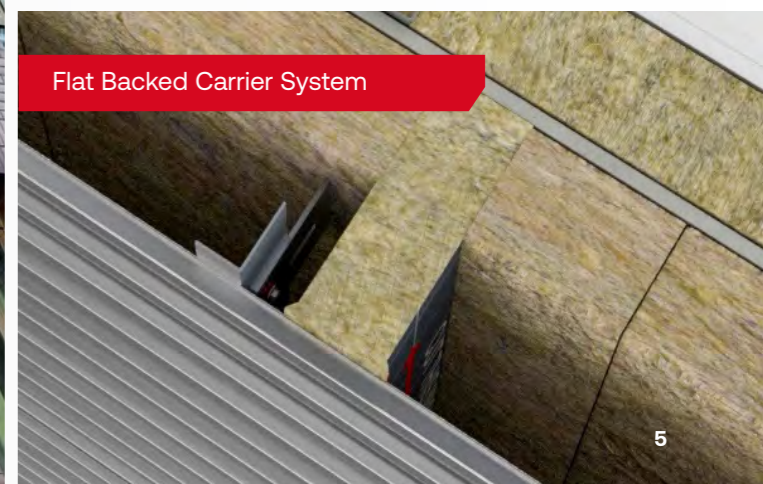
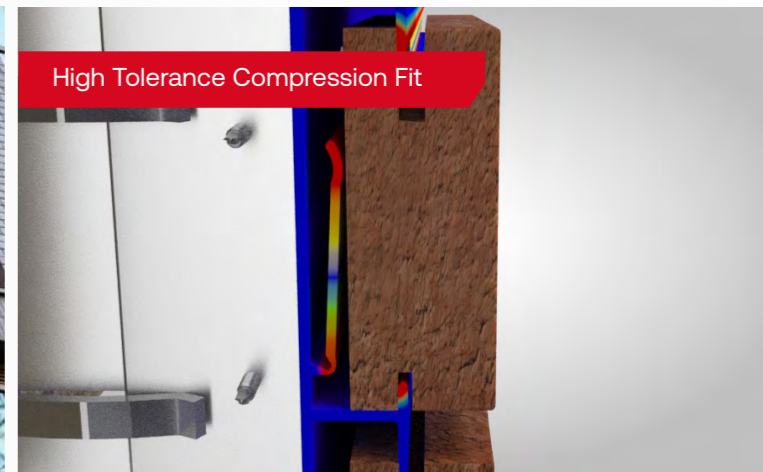

Scan to view the
Occam Brick Slip on the NBS



Scan to view the
Occam Clay Tile on the NBS



TimelessStaple



ModernContemporary



Testing & Certification

The Occam system has undertaken a rigorous testing regime to ensure its compliance with the latest building regulations.

The Occam Brick Cladding Systems have a UL Mark product certification, which is a scheme recognised by NHBC and other leading warranty providers. UL Solutions are a global service provider that offers testing and product certification for a wide range of sectors including building envelopes and facade performance.

Testing & Certification



A1 Fire Rated

Non-combustible, mechanically fixed and classified A1 in accordance with EN 13501-1.



Hygrothermal Behaviour

Cyclic environmental testing has been undertaken in accordance with EAD 090062-01-0404.

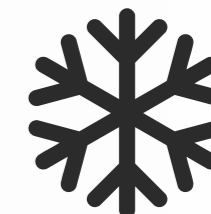

Freeze-Thaw Resistance

Freeze-thaw cyclic loading has been undertaken in accordance with EAD 090062-01-0404.



Water Tightness

Water penetration resistance testing has been undertaken in accordance with CWCT test sequence B.



Wind Resistance

A serviceability load of 2.4kN/m² and safety load of 3.6kN/m² were successfully applied in accordance with CWCT test sequence B.



Impact Performance

Achieves upto Class 2 negligible risk for impact performance in accordance with CWCT TN75 & TN76.



3rd Party Certification

UL Mark is a product certification scheme recognised by NHBC and other leading warranty providers.

Swift Installation

This is a quick reference guide to the assembly of the Occam system. Comprehensive installation literature and training is available upon request.

Our streamlined installation process outpaces traditional bricklaying, beginning with a completely plumb and level starter carrier that starts the installation process. The subsequent carriers stack into place with great precision, while our inventive tongue compression technology creates satisfying engagement with a secure compressive fit for each brick unit.

Installation Guide

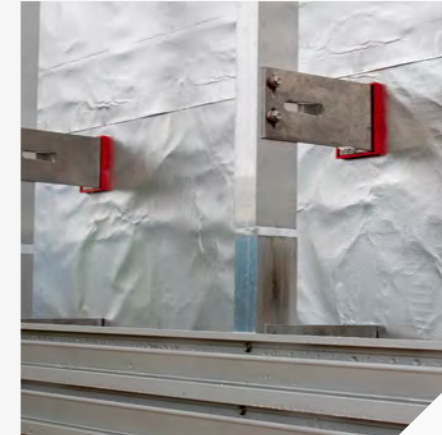

Stage 1

Helping hand brackets and vertical rails are installed at specified centres to the substrate.



Stage 2

Position the starter carrier horizontally and ensure it is level before fixing in position.



Stage 3

Stack the following carrier onto the previously fixed carrier and fix again at the specified centres.



Stage 4

Clear any debris from the carriers before commencing to the next stage of the brick installation.

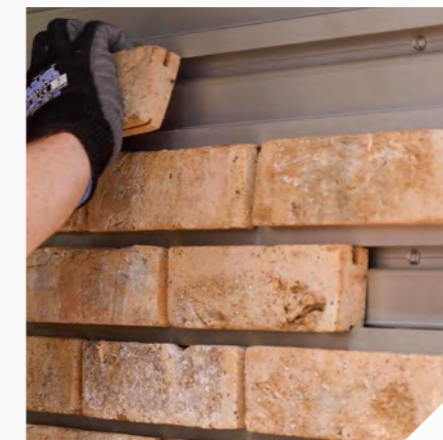

Stage 5

Insert the bricks top edge first, rotate in the bottom edge and engage into the carrier tongue, then pull down the brick to fully engage.



Stage 6

Set all joints to nominal 10mm, the joints should then be filled with pointing mortar and tooled to finish.



Scan to watch the Occam Brick Slip Installation Video



Scan to watch the Occam Clay Tile Installation Video

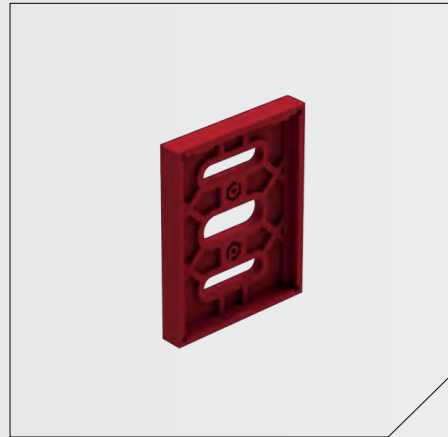

● 80mm Isolator Pad

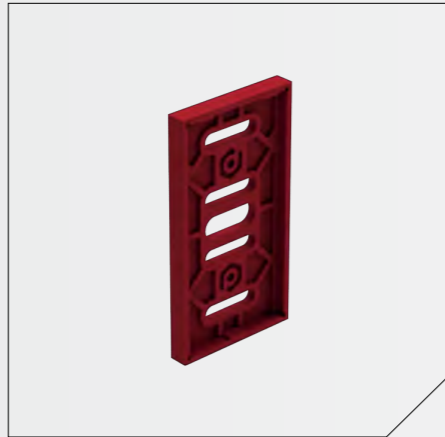

● 120mm Isolator Pad

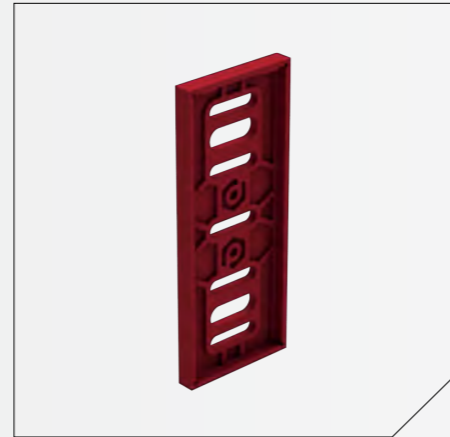

● 160mm Isolator Pad

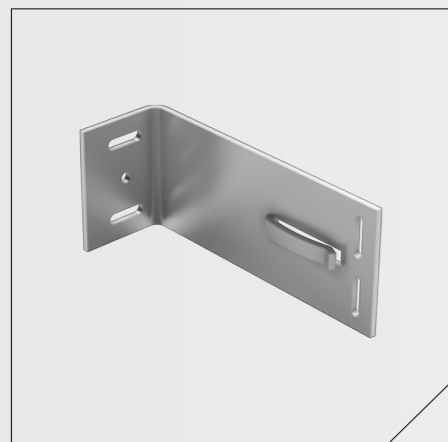

● 80mm Helping Hand Bracket

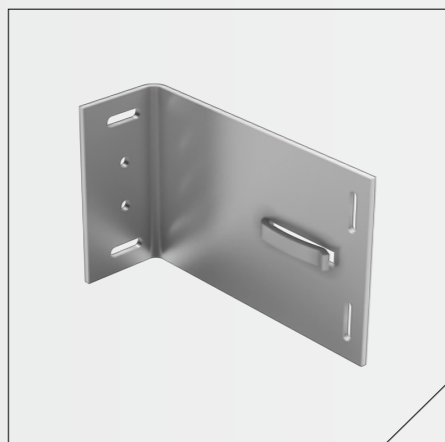

● 120mm Helping Hand Bracket

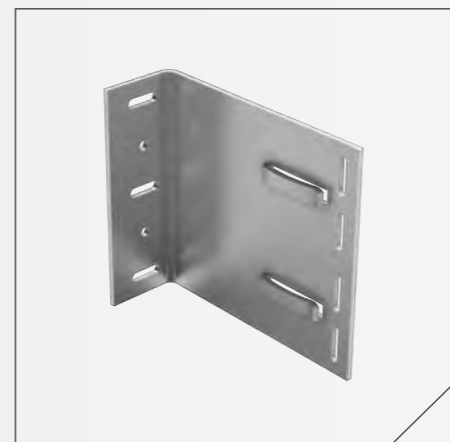

● 160mm Helping Hand Bracket

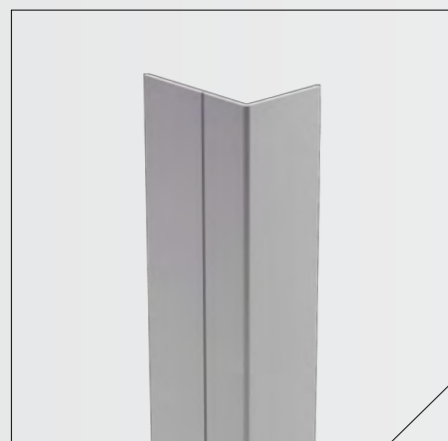

● L Rail

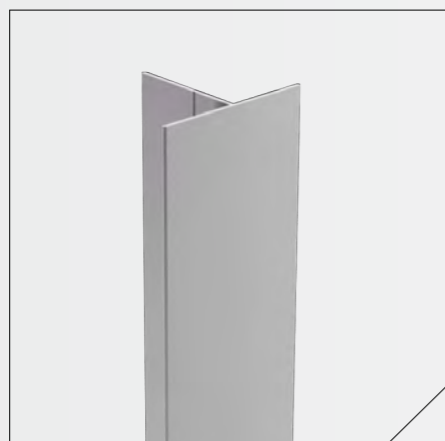

● T Rail

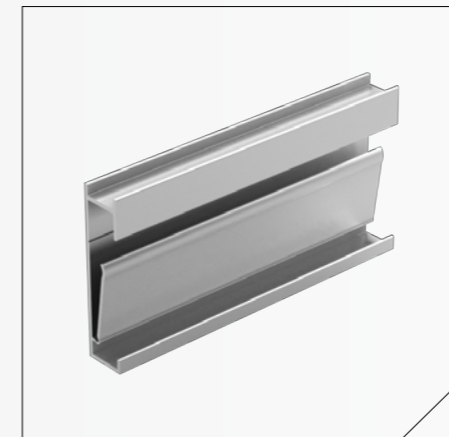

● Starter Carrier



● Single Carrier

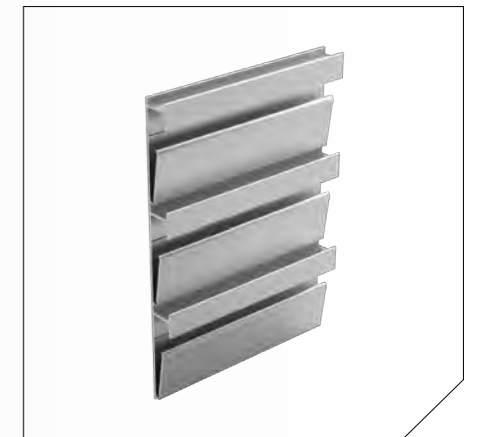

● Triple Carrier

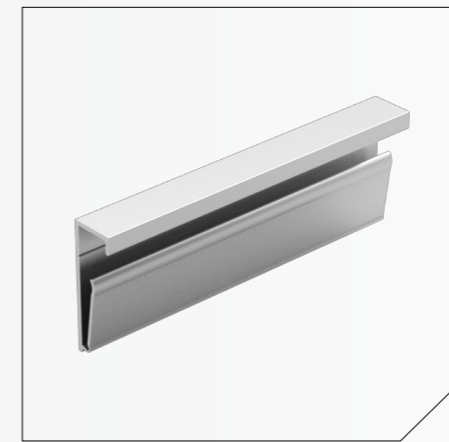

● Termination Carrier (Brick Slip)

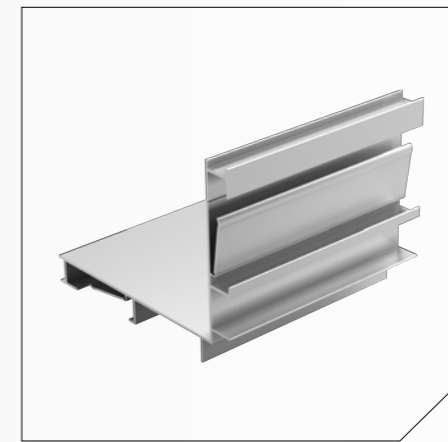

● Soffit Carrier (Brick Slip)

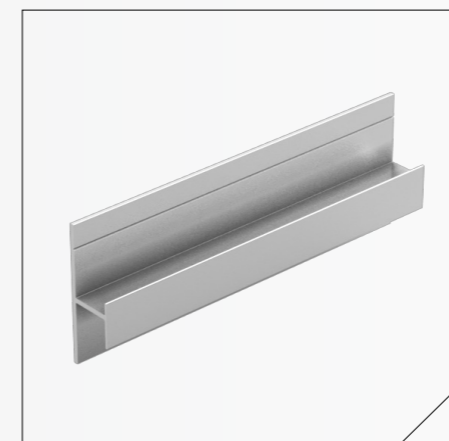

● Termination Carrier (Clay Tile)

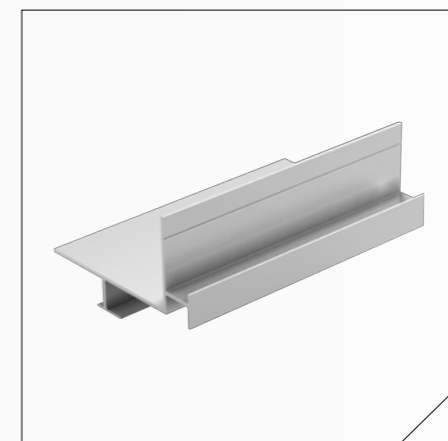

● Soffit Carrier (Clay Tile)



● Standard Brick Slip



● Projecting Brick Slip



● Pistol Brick Slip



● Soldier Pistol Brick Slip



● Soffit Brick Slip



● Single Height 65mm Clay Tile



● Projecting Clay Tile



● Corner Clay Tile



● Soldier Corner Clay Tile



● Soffit Clay Tile



● Double Height 140mm Clay Tile



● Triple Height 215mm Clay Tile

Bring brilliant bond patterns and features to your design.

Our modern design creates dynamic shadows and dimensional depth, bringing unique visual interest to your building's exterior.

The continuous system carrier has the ability to work in perfect harmony with traditional brickwork in horizontal and vertical applications whilst not being restricted by conventional height restrictions.



Soldier Bond

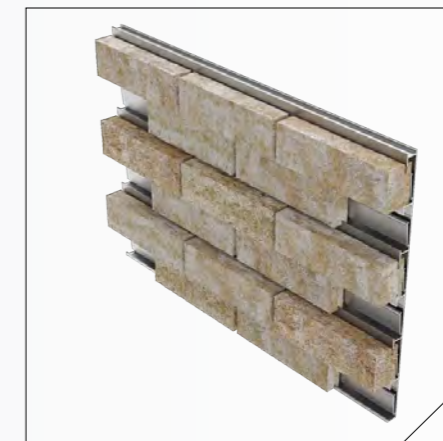

Projecting Stretcher Bond (20mm)

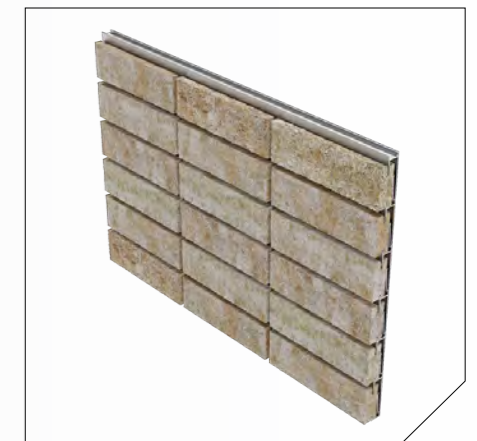

Stack Bond



Fishscale Bond



Projecting Flemish (20mm)



Stretcher Bond

Occam Brick Slip Range

We collaborate with industry leading manufacturers like Wienerberger, Ibstock, Vandersanden, Caprice and many more

We offer an unmatched range of brick possibilities. Our system accommodates various types of facing bricks within the T2 R1 tolerance range or better. From traditional Wirecut and Waterstruck to elegant Stock and artisan Handmade styles, spanning over virtually limitless unique finishes.



Explore Our Virtually Unlimited Brick Range

Swatches shown are a small selection. View the full range with your representative.

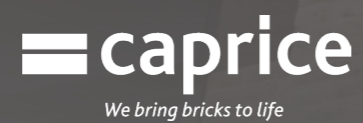

The swatches shown are a small selection of the range available. Speak to your representative to discuss the full range.

Red



Redhill Multi

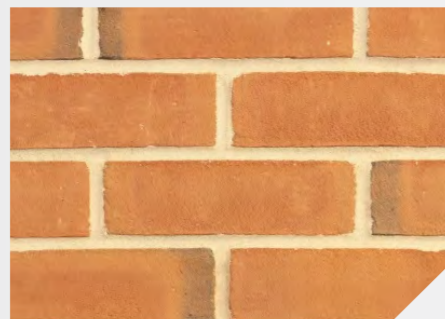

Cornell Orange



Cayenne



Tornado Waterstruck

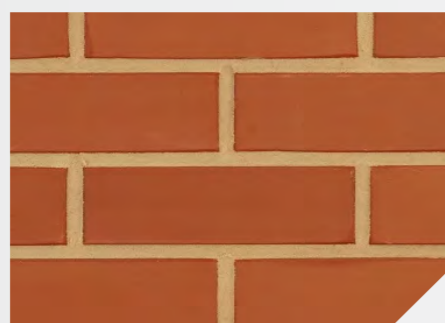

Salford Smooth

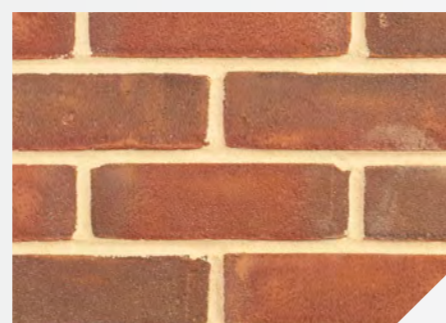

Primrose Red



Gala Red

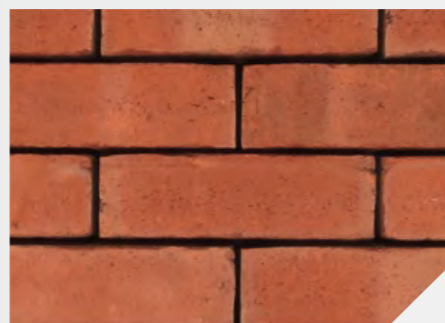

Worsley Red



Anglian Red Stock



Carden Red



Lytham Multi



Harpened Weathered

The swatches shown are a small selection of the range available. Speak to your representative to discuss the full range.



Gathurst Multi



Scala Red



Mere Blend



Hartford Red



Baccara



Telica Waterstruck



Heywood Red



Mottram Multi

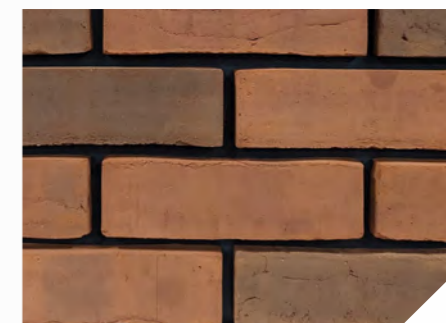

Norley Red

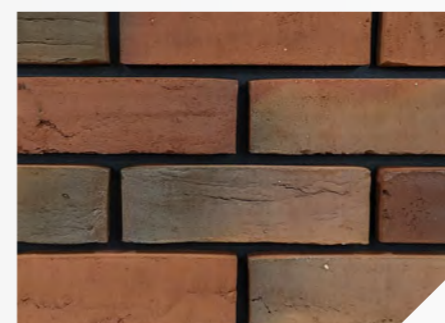

Delamere Red Multi

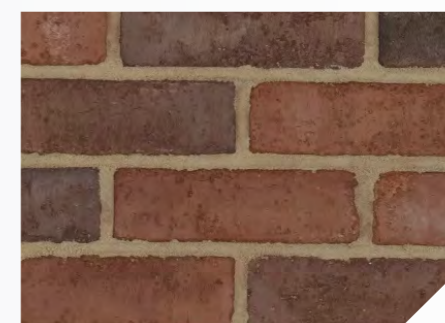

Wilmslow Orange

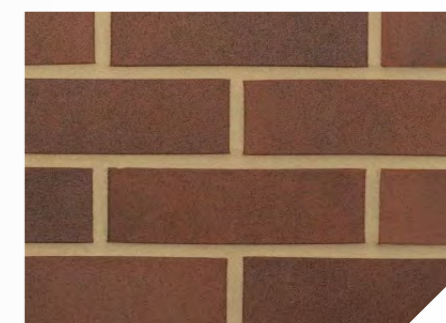

Clayton Multi

The swatches shown are a small selection of the range available. Speak to your representative to discuss the full range.

Yellow & Buff



Creme

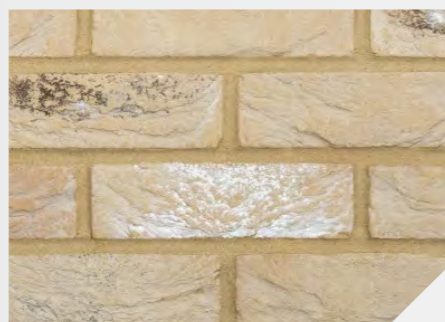

Broadstone Buff



Mirato White



Rose



Higgins Buff



Caversham



Weathered Cream Handmade



Corum



Liza Waterstruck



Smooth Buff

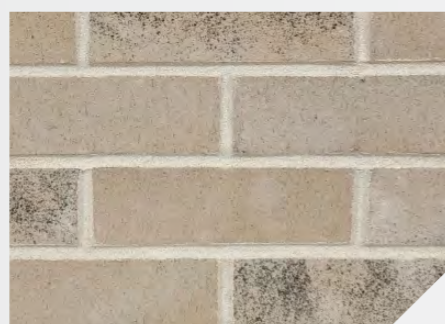

Collyhurst Yellow



Ledbury

The swatches shown are a small selection of the range available. Speak to your representative to discuss the full range.

Grey, White & Dark



Polar White Smooth



Lima



Bivio

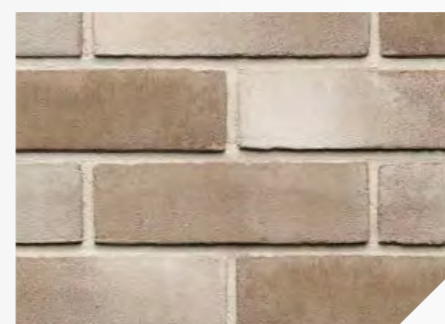

Bromo Stock



Quartis

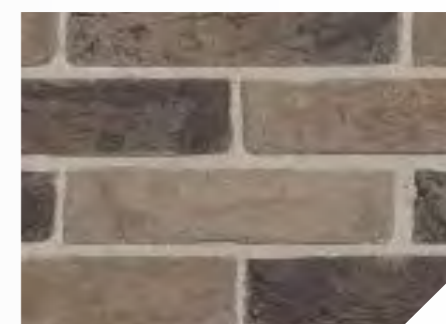

Cortona

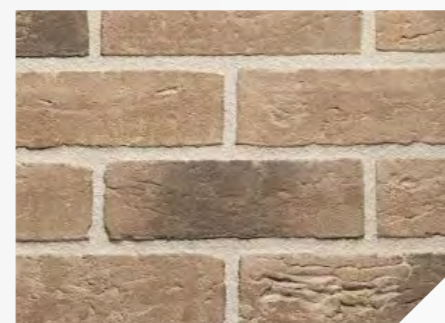

Fuji Handmade



Birkdale Blend



Caldera

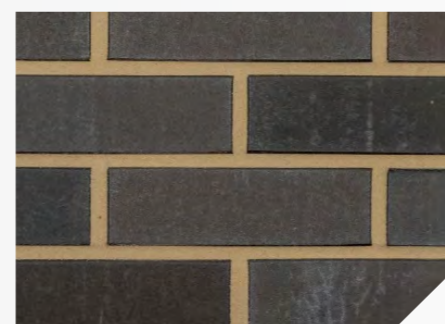

Midnight Blue

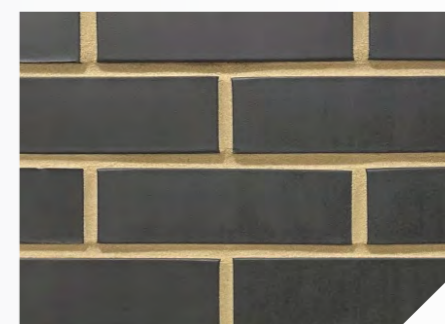

Black Smooth

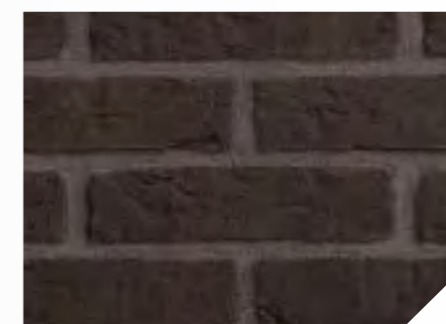

Midnight Blue VDS

Print Perfect

Release your creativity with Occam's revolutionary Print Perfect brick technology.

Involving advanced digital engraving technology, transform your traditional clay bricks into stunning, fully customisable design elements. From a virtually limitless colour palette spanning the entire RAL spectrum to an array of captivating textures smooth, speckled, and rugged, we offer bespoke brick solutions that turn your ideas into existence.



3D Printed Bricks
Any Brick
Any Colour
Any Finish



Clay Tile Range

The swatches shown are a small selection of the range available. Speak to your representative to discuss the full range.

[Zoom in to explore colours and fine details](#)

Brick Tile Range



Pale Ridge



Pale Haze



Ambleside Mist



Eastbourne Beach



Flaxseed Oil



Wensleydale Blend



Sandbrush



Oatmere



Hampton Court



Cinder Bloom



Chalk Cliff



Chestnut Ember

The swatches shown are a small selection of the range available. Speak to your representative to discuss the full range.

🔍 *Zoom in to explore colours and fine details*

Brick Tile Range



Stained Novella

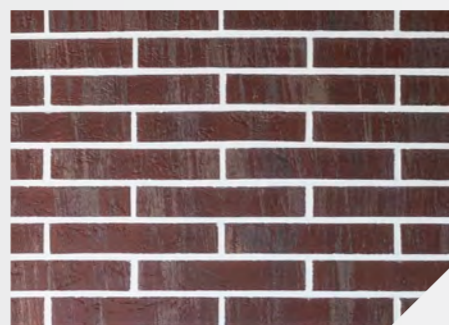

Canal Bridge

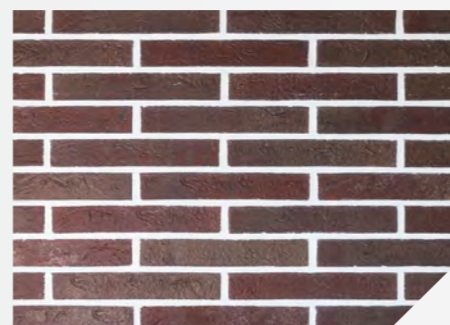

Yorkshire Rose

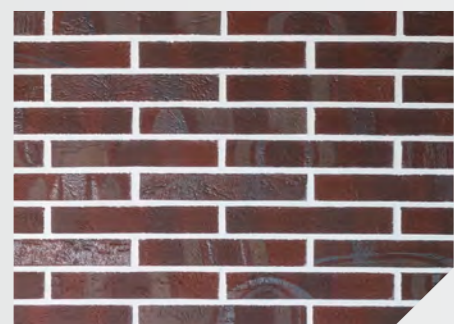

Emberwood

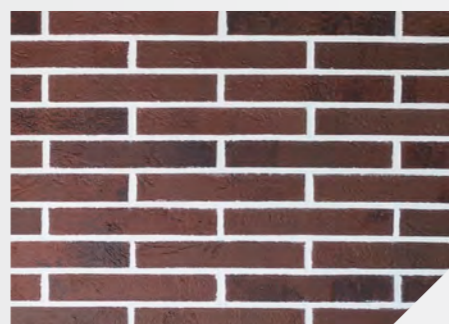

Midnight Ember



Auburn Ash

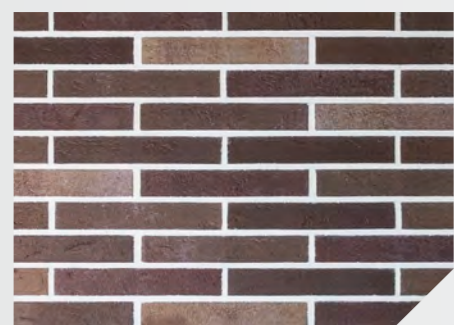

Tweed Heather



Smoked Umber



Cinder Oak

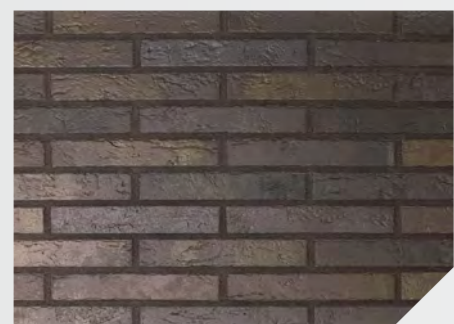

Penny Lane

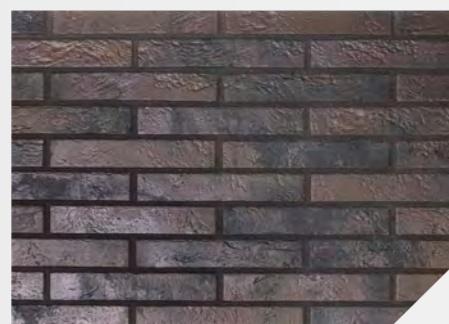

Ebonfield



Ashbourne

The swatches shown are a small selection of the range available. Speak to your representative to discuss the full range.

🔍 *Zoom in to explore colours and fine details*

Brick Tile Range

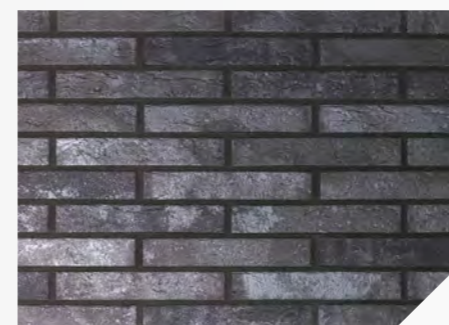

Smoke Signal

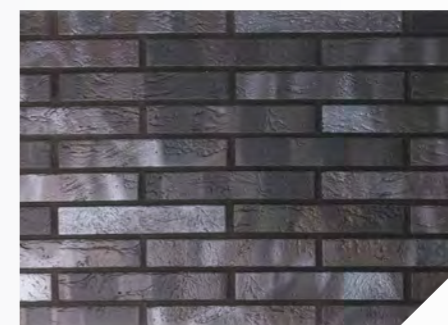

Moorland

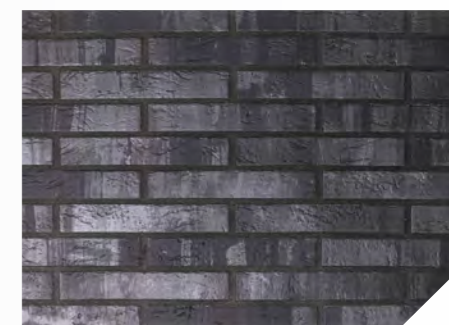

Iron Granite

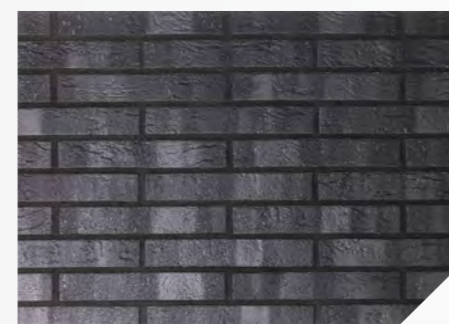

Charcoal Ridge



Coal Mine

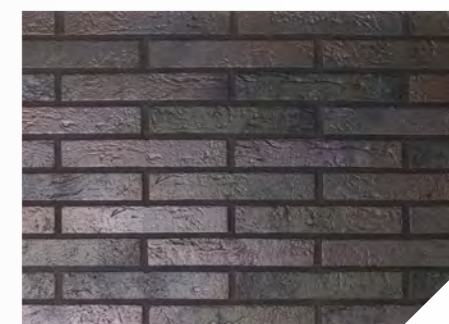

Bantham

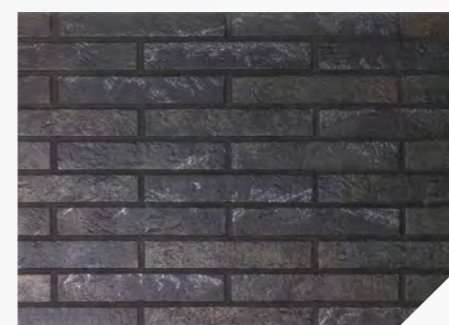

Concrete Forest

The swatches shown are a small selection of the range available. Speak to your representative to discuss the full range.

Glazed



The swatches shown are a small selection of the range available. Speak to your representative to discuss the full range.

Metallic Glazed

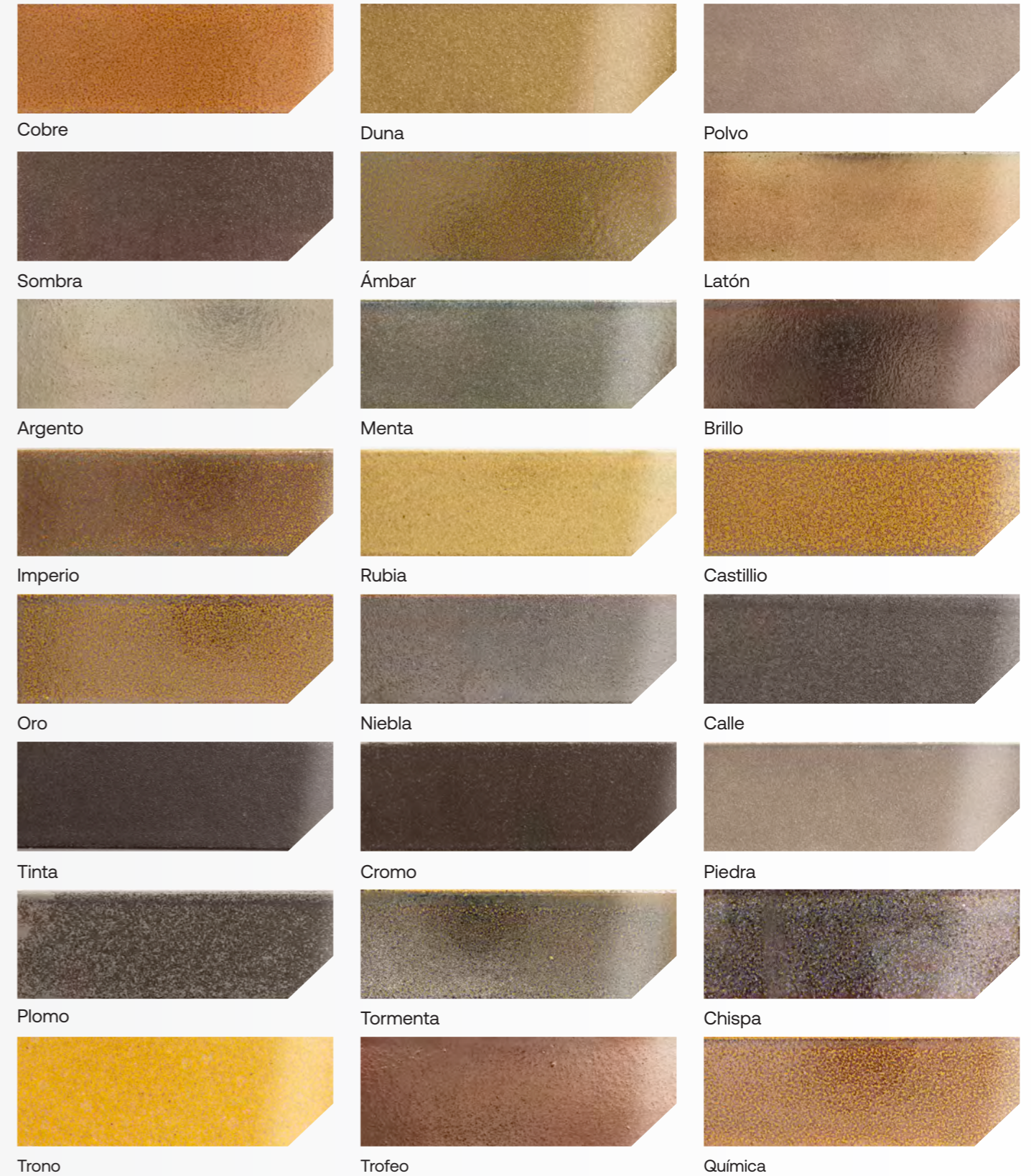



Create a harmonious finish with a wide range of mortar options

Occam offers a range of pointing mortars including Instarmac Limepoint PF & Sika Parex Historic KL.

Pointing mortar is a traditional hydrated lime, sand and ground granulated blast furnace slag mortar (GGBS). It is dry packed with a blend of lime including selected GGBS, silica sands and natural aggregates, together with additives to provide water resistance, thixotropic properties, workability and colour.

Below are the colour options from the Instarmac range of pointing mortar.



Natural



Portland



Light Grey



Mid Grey

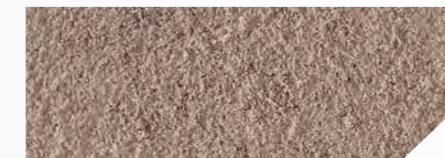

Light Brown



Mid Brown

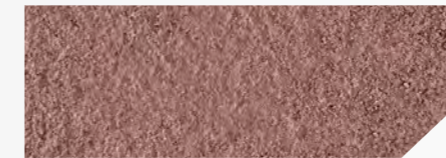

Brick Red

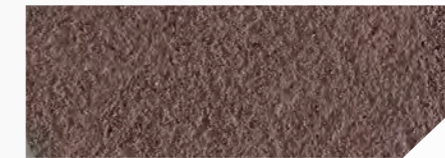

Dark Red



Sandstone

INSTARMAC



Scan to view the full range of mortar from Instarmac



Scan to view the full range of mortar from Sika

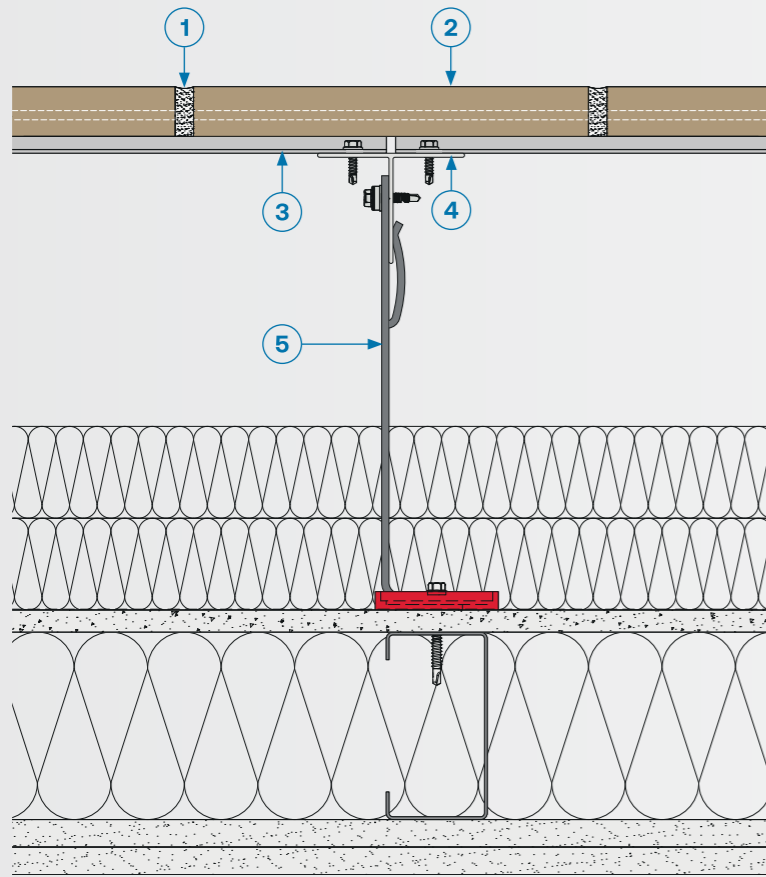

Brick to Brick Horizontal

1. Pointing Mortar
2. Occam Brick Slip
3. Occam Triple Carrier
4. Aluminium Extruded "L" or "T" Rail
5. Helping Hand Support Bracket

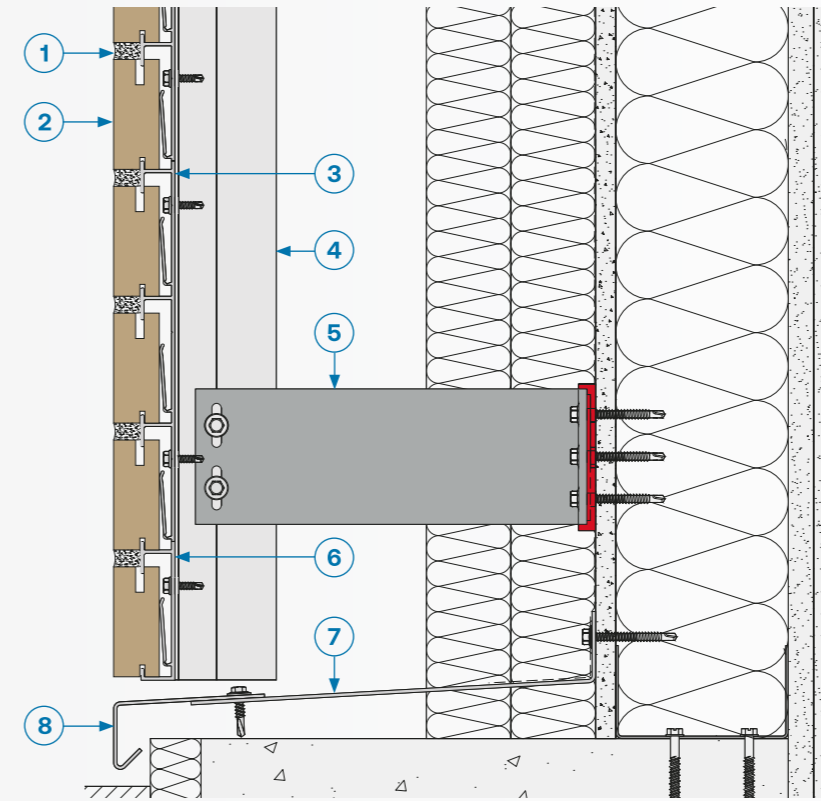

Brick to Base

1. Pointing Mortar
2. Occam Brick Slip
3. Occam Triple Carrier
4. Aluminium Extruded "L" or "T" Rail
5. Helping Hand Support
6. Occam Starter Carrier
7. Proteus Base Support Flashing
8. Proteus Base Flashing

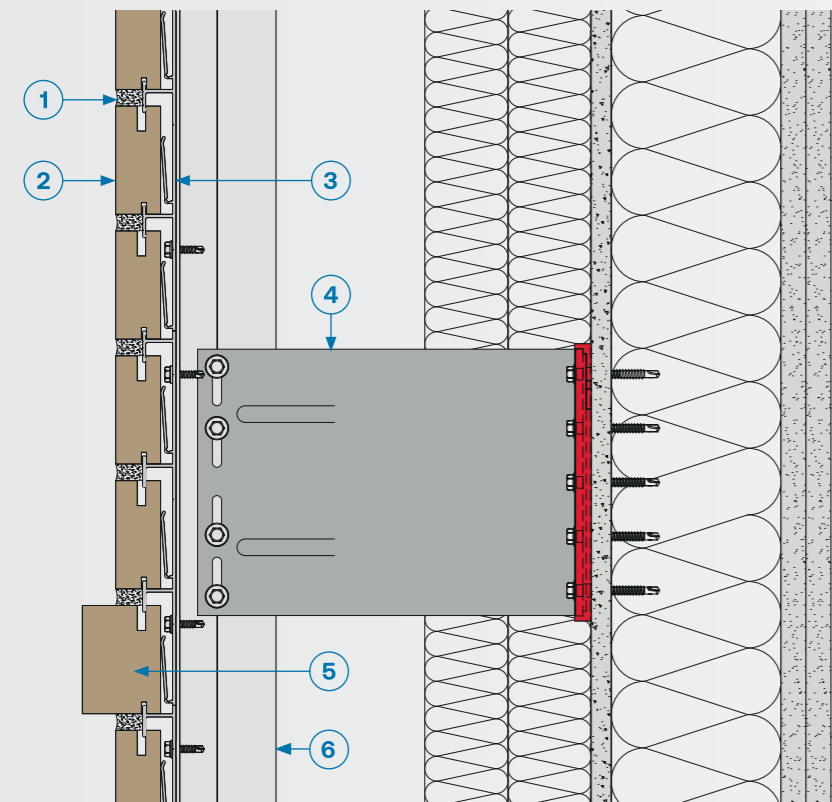

Brick to Brick Vertical

1. Pointing Mortar
2. Occam Brick Slip
3. Occam Triple Carrier
4. Helping Hand Support Bracket
5. Projecting Brick (Optional)
6. Aluminium Extruded "L" or "T" Rail

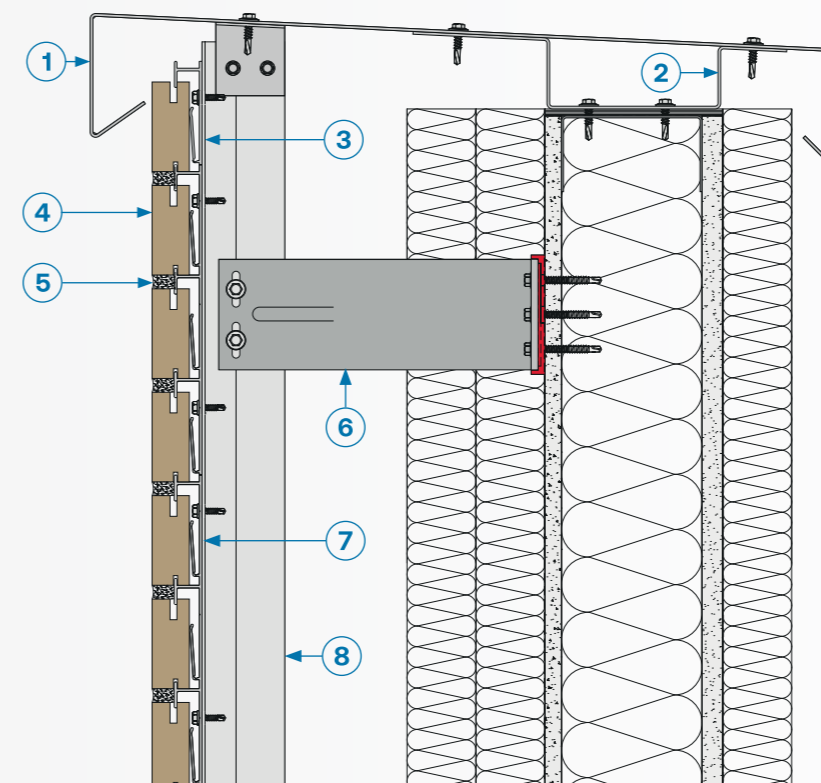

Brick to Capping

1. Proteus Capping Flashing
2. Proteus Capping Support Flashing
3. Occam Single Carrier
4. Occam Brick Slip
5. Pointing Mortar
6. Helping Hand Support Bracket
7. Occam Triple Carrier
8. Aluminium Extruded "L" or "T" Rail

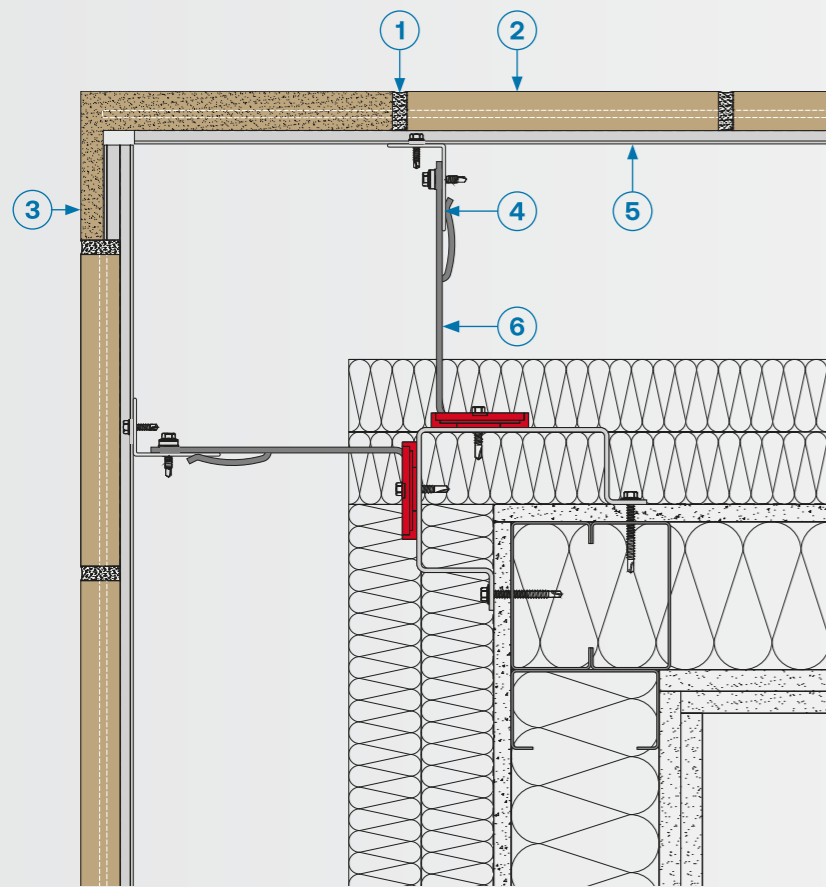

External Corner Brick to Brick

1. Pointing Mortar
2. Occam Brick Slip
3. Occam Pistol Brick
4. Aluminium Extruded "L" or "T" Rail
5. Occam Triple Carrier
6. Helping Hand Support Bracket

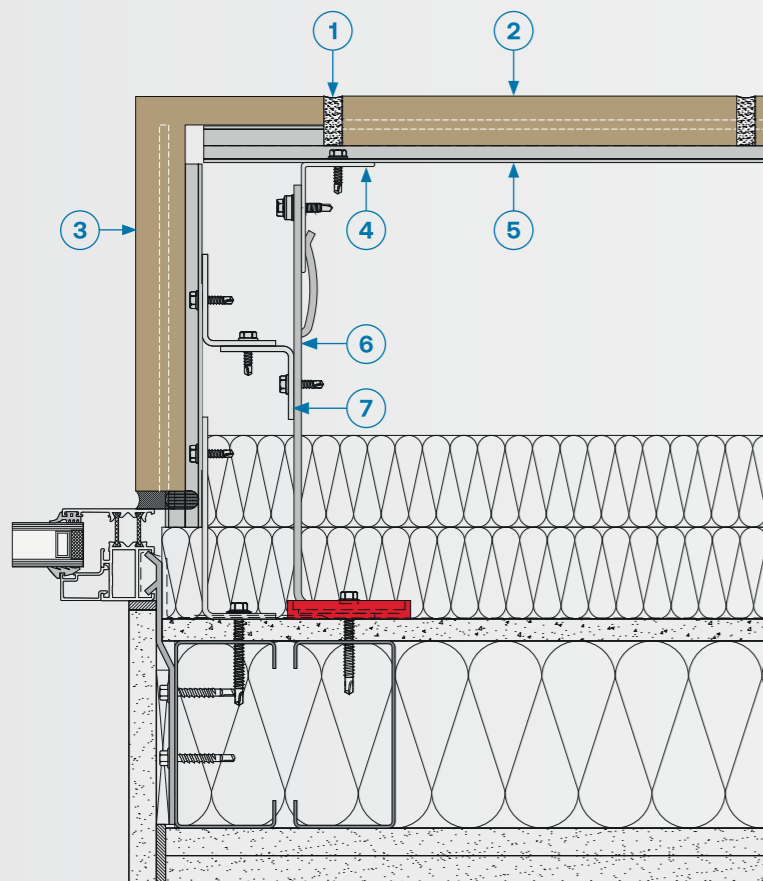

Brick to Window Jamb

1. Pointing Mortar
2. Occam Brick Slip
3. Occam Pistol Brick
4. Aluminium Extruded "L" or "T" Rail
5. Occam Triple Carrier
6. Helping Hand Support Bracket
7. Jamb Support Arrangement

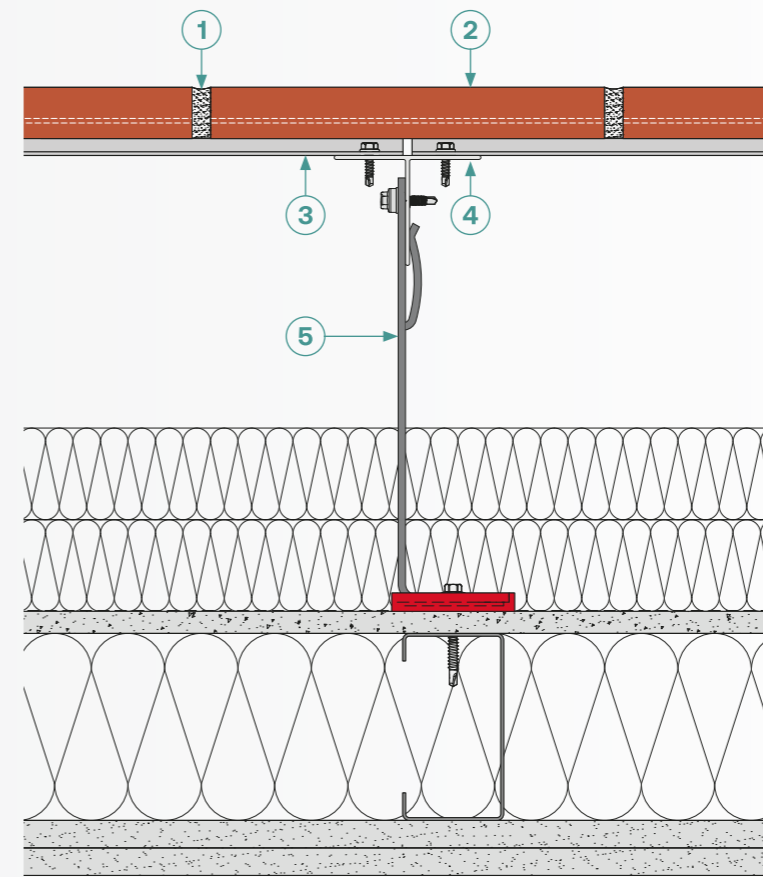

Brick to Brick Horizontal

1. Pointing Mortar
2. Occam Clay Tile
3. Occam Triple Carrier
4. Aluminium Extruded "L" or "T" Rail
5. Helping Hand Support Bracket

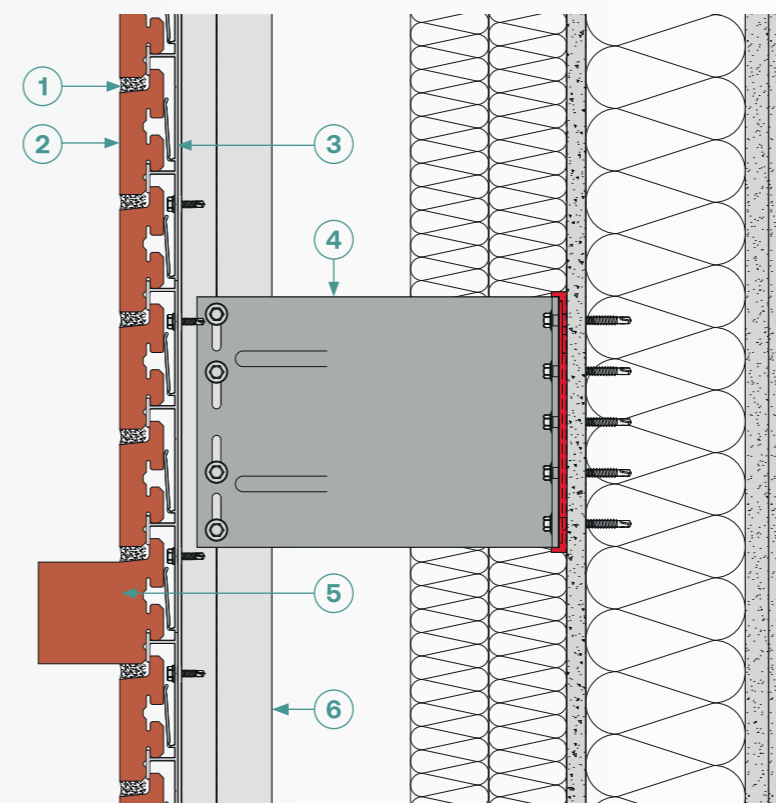

Brick to Brick Vertical

1. Pointing Mortar
2. Occam Clay Tile
3. Occam Triple Carrier
4. Helping Hand Bracket
5. Projecting Brick (Optional)
6. Aluminium Extruded "L" or "T" Rail

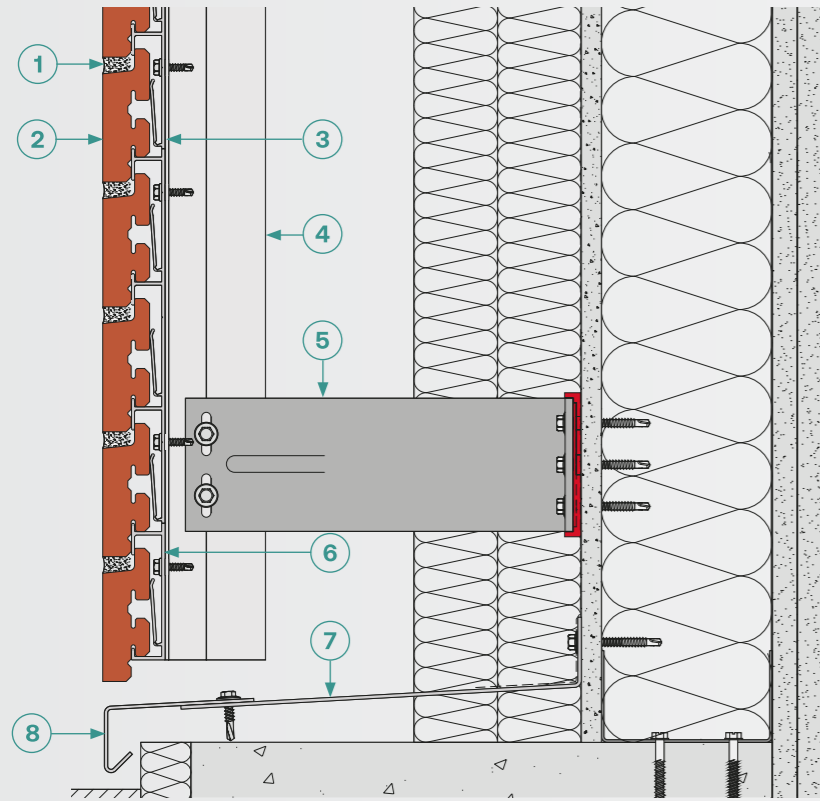

Brick to Base

1. Pointing Mortar
2. Occam Clay Tile
3. Occam Triple Carrier
4. Aluminium Extruded "L" or "T" Rail
5. Helping Hand Support
6. Occam Starter Carrier
7. Proteus Base Support Flashing
8. Proteus Base Flashing

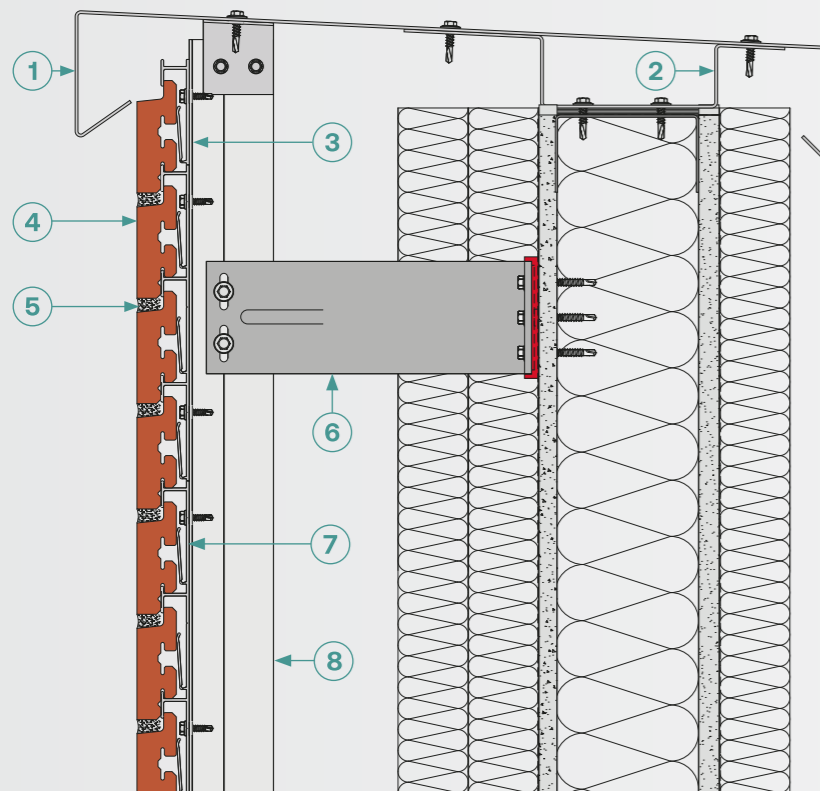

Brick to Capping

1. Proteus Capping Flashing
2. Proteus Capping Support Flashing
3. Occam Single Carrier
4. Occam Clay Tile
5. Pointing Mortar
6. Helping Hand Support Bracket
7. Occam Triple Carrier
8. Aluminium Extruded "L" or "T" Rail

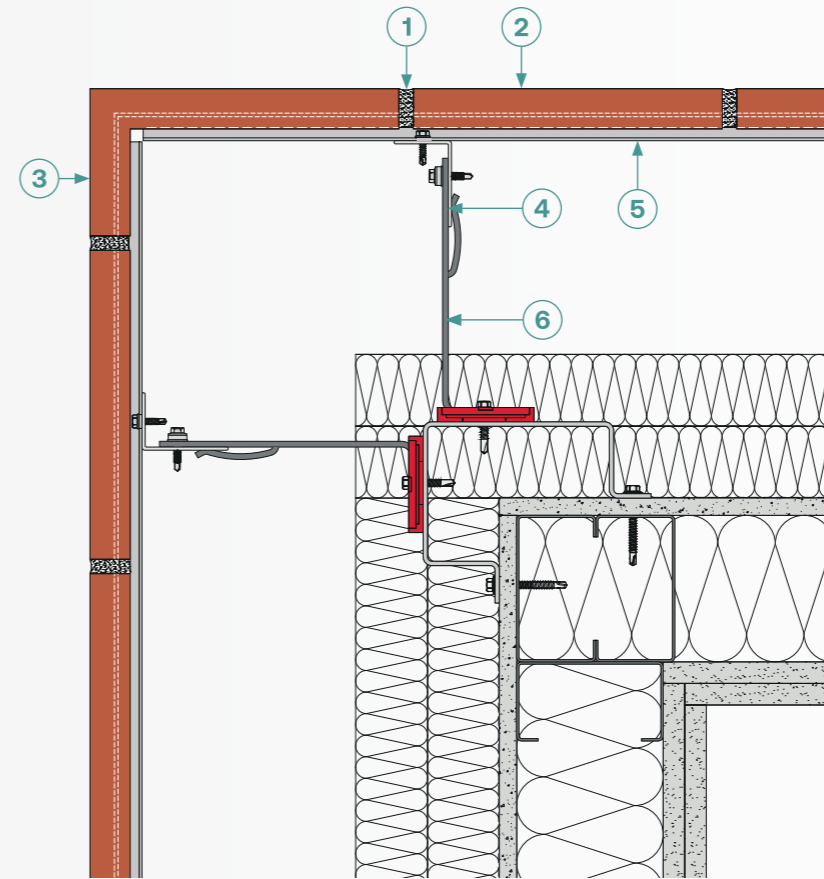

External Corner Brick to Brick

1. Pointing Mortar
2. Occam Clay Tile
3. Occam Corner Tile
4. Aluminium Extruded "L" or "T" Rail
5. Occam Triple Carrier
6. Helping Hand Support Bracket

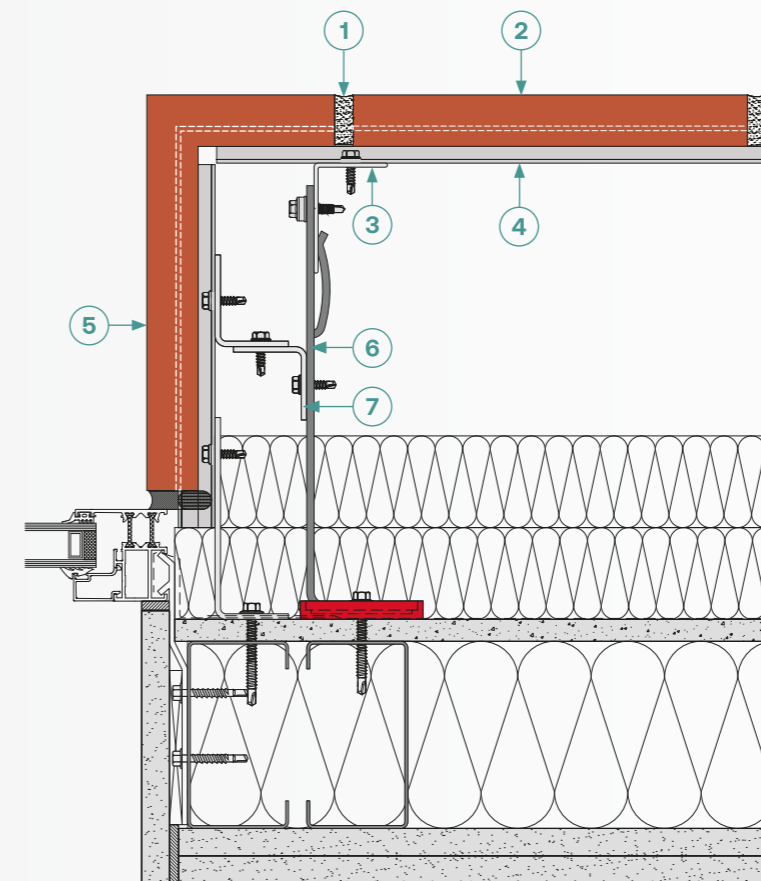

Brick to Window Jamb

1. Pointing Mortar
2. Occam Clay Tile
3. Aluminium Extruded "L" or "T" Rail
4. Occam Triple Carrier
5. Occam Corner Tile
6. Helping Hand Support Bracket
7. Jamb Support Arrangement



Our Partners

Partnering with the UK's leading brick specialist.

Embark on a tactile journey through our UK showrooms, where inspiration meets invention.

Where you can physically explore an extensive array of brick samples, touch premium products, and engage directly with our expert brick specialists. Our showroom offer a comprehensive display environment designed to guide you through selecting the perfect brick solution for your project.

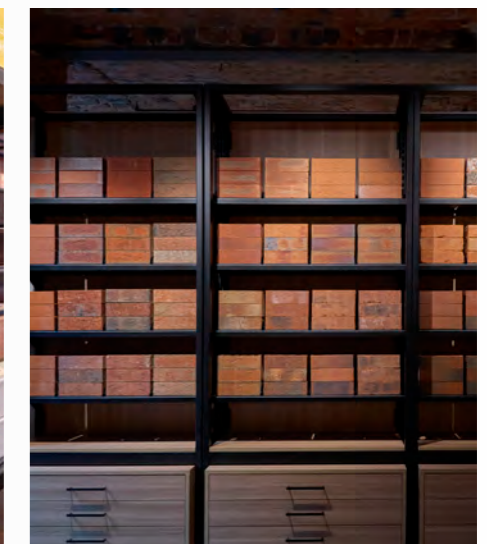
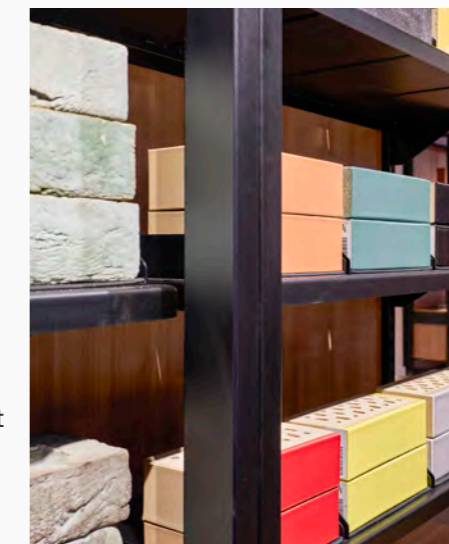
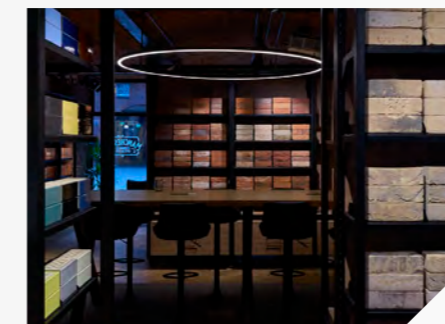
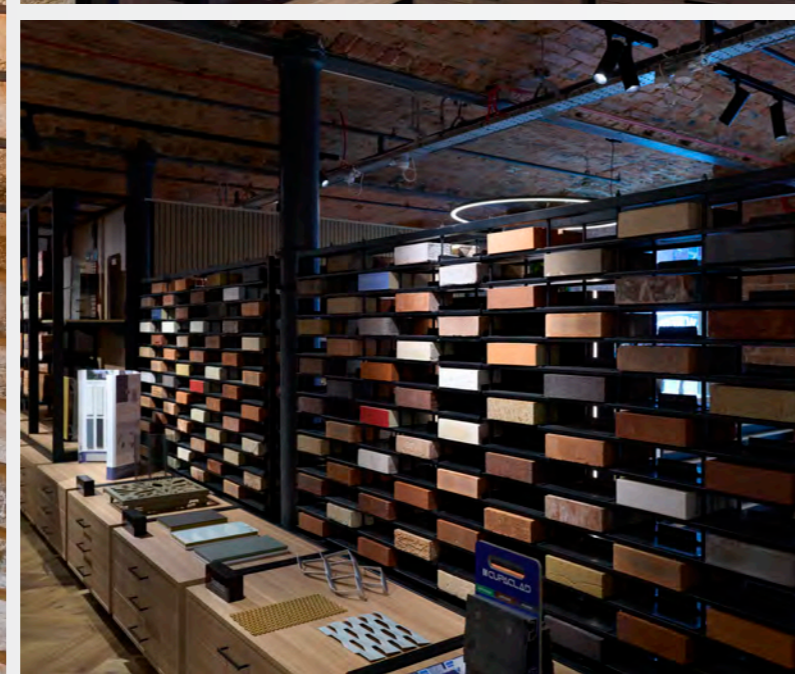
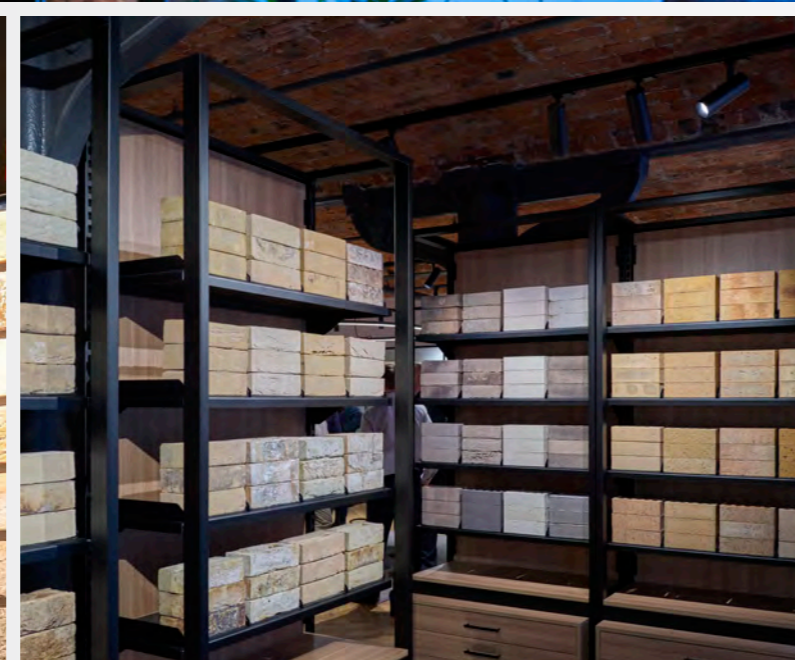
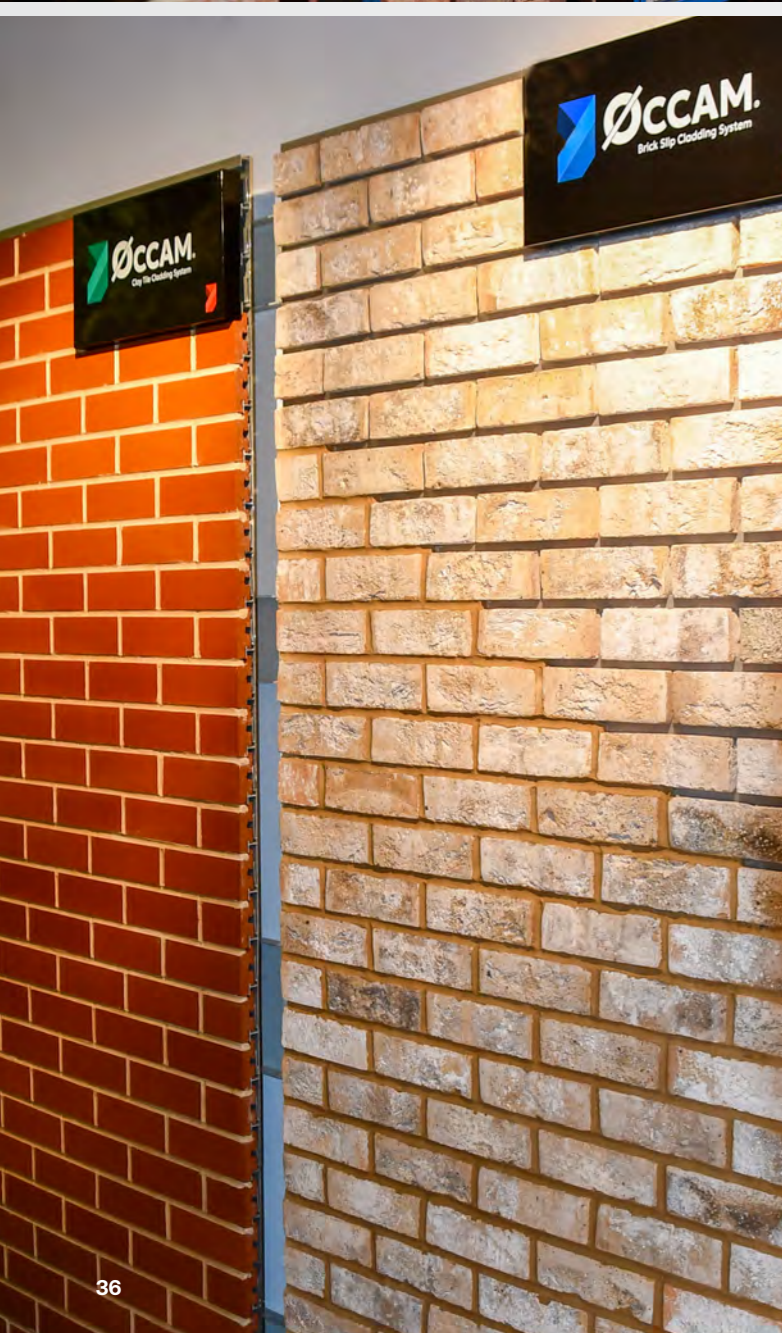

MBS Facades

Address: Unit 3 Royal Mills, 17 Redhill St
Ancoats, Manchester, M4 5BA

Email: sales@manchesterbrick.com

Tel: +44 (0)161 641 3579





MBS Facades

Unit 3 Royal Mills, 17 Redhill St
Ancoats, Manchester, M4 5BA

+44 (0)161 641 3579
sales@manchesterbrick.com

Published date: 07/25
Version: 2.0